



Fraunhofer

CBP

FRAUNHOFER CENTER FOR CHEMICAL-
BIOTECHNOLOGICAL PROCESSES CBP

CHEMICAL PROCESSES

STIRRED TANK REACTOR



The Fraunhofer Center for Chemical-Biotechnological Processes CBP in Leuna, central Germany, closes the gap between the lab and industrial implementation. By making infrastructure and plants (pilot scale and miniplants) available, the center makes it possible for cooperation partners from research and industry to develop and scale up biotechnological and chemical processes for the utilization of renewable raw materials right up to industrial scale.

This field of work focuses on the process-technological development of chemical processes to produce biobased basic and fine chemicals for further processing in the chemical, pharmaceutical or food industries. In addition to new process concepts, the optimization of the resource and energy efficiency of existing processes also plays an important role here. Established processes can be adapted and optimized from the ecological and economic viewpoint. In doing this, we both consider biobased raw materials and also examine conventional processes for manufacturing petrochemical products.



PORTFOLIO

The batch reactor is a discontinuously operated stirred reactor and suitable for carrying out homogeneously and heterogeneously catalyzed reactions in the gas and liquid phase of aqueous or solvent-containing systems. The 50-liter reactor permits temperatures up to 300°C and pressures up to 98 bar. There is a continuous gas supply with nitrogen, oxygen, hydrogen and ammonia.

Technical data

- ATEX-compliant unit (zone 2b+H2, T3)
- Volume 50 liters
- Pressure max. 98 bar
- Material Hastelloy C-22
- Temperature max. 300°C
- Rapid cooling
- Skew blade gas injection stirrer
- Robinson-Mahoney type catalyst basket
- Gas dosing of O₂ and H₂ controlled by means of mass flow controller (MFC)

PROCESS

Heterogeneously catalyzed production of sorbitol from glucose using Raney nickel

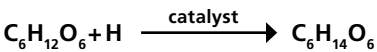

First the reactor is rinsed with N_2 and then filled with the educt mixture water/glucose and the catalyst suspension.

In the second step the reactor is pressurized with H_2 to a maximum of 98 bar and the mass flow rate control for continuous supply of hydrogen is activated. The temperature control is set to 120°C . All measured values are documented with a data logging system. After completion of the reaction the cooler is activated and the reactor pressure is decreased. Then, after a final inertization, the sorbitol mixture can be removed from the reactor via the product discharge device.



FLOW CHART OF THE STIRRED TANK REACTOR

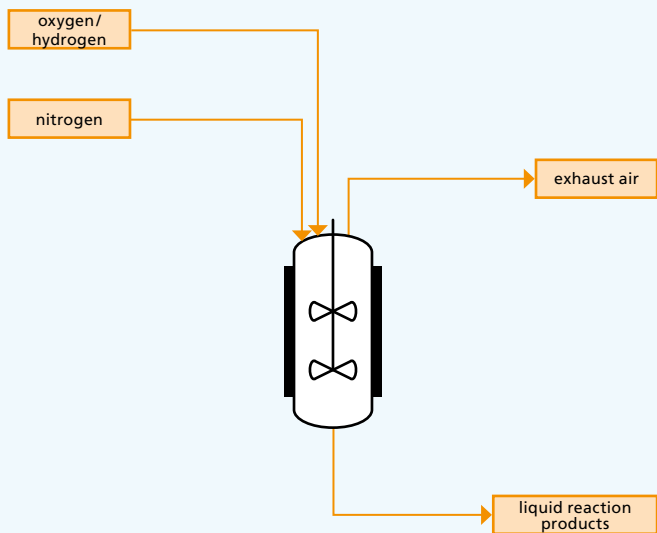

CONTACT

Fraunhofer Center for Chemical- Biotechnological Processes CBP

Am Haupttor (Gate 12, Building 1251)
06237 Leuna | Germany
www.cbp.fraunhofer.de

Ulrike Junghans M. Sc.

Group Manager Chemical Processes
Phone +49 3461 43-9128
ulrike.junghans@igb.fraunhofer.de

Robert Röver M. Eng.

Project Manager for Chemical Processes
Phone +49 3461 43-9115
robert.roever@igb.fraunhofer.de